

Main rooms 44,804 m<sup>2</sup>  
 Loft - m<sup>2</sup>  
 Terrace 8,550 m<sup>2</sup>  
**Total: 53,354 m<sup>2</sup>**

## Cumbrae Cabin

### 53m<sup>2</sup>

Dimensions (PxG): 5,82x8,12 m

Wall thickness: 45 mm / 60 mm / 95 mm

Side wall height: 2,21 m

Roof incline : 18,3°

Roof overhang: 150/20/30/30 cm

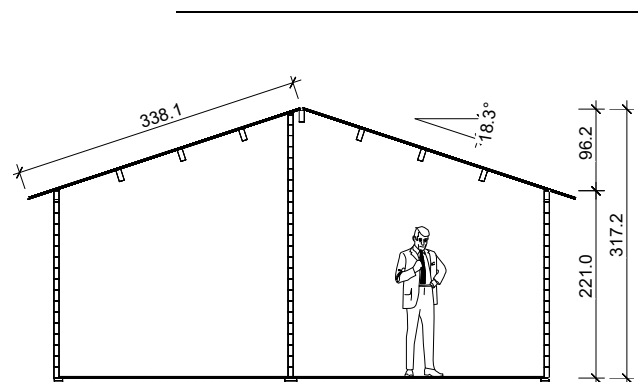

**Consists of:**

**Ground floor:** floor joists (h-6,0cm), floor boards 20mm thick ,trimmings

**Walls :** profiled logs (h-13cm), notches – 10cm.  
Metal bars in the corners .

**Roof:** 7 rafters 6,0x14,0cm ,ceilling boards 20mm , fascias, roof incline 18,3°( adjusted for light roof cover).

**Doors :** solid single , 5 points locking, aluminium bottom frame :

1unit 100x203cm(DN-10-1/2)

Solid single :

2 units 90x197cm(DF-9-0)

1 units 80x197cm(DF-8-0)

**Windows :** tilt&turn double glazed:

2 DBL 120x94cm (NF-12),

4 SGL 80x94cm (NF-8),

1 SGL 56x62cm (NF-5-1).

**additional Options:**

**Roof Coating**

Shingles

